

Conversion of 6995 Mk II Membrane Dehydrator to 6995 Mk III

I. Purpose.

The purpose of this tech sheet is to describe the conversion of an HLI Model 6995 Mk II (30 SCFM rated dehydrator) to an HLI Model 6995 Mk III (15 SCFM rated dehydrator.) A reduction in outlet dry-air flow rate also reduces the purge air requirements.

II. Materials required for conversion.

Kit, Model 6995 Mk II to III conversion P/N 9023-01; contains:

- Blank body, 1/2" P/N 5075-04T-8, Qty 4
- Blank body, 1/4" P/N 5075-04T-4, Qty 2
- O-ring P/N M83248/2-015, Qty 2
- O-ring P/N M83248/2-011, Qty 2
- Label plate P/N 6995-G503-801, Qty 1
- Label plate P/N 6995-G503-802, Qty 1
- Label plate P/N 6995-G503-813, Qty 1
- Label plate P/N 6995-G503-803, Qty 1
- Drive screws, Qty 10

III. Procedure.

- Shut down the dehydrator per Paragraph 2.3.3 of the technical manual. Observe all precautions.
- Identify the two membrane elements to be removed (Figure 1).
- Disconnect the inlet manifold assembly (Figure 2, 1) from the fittings (2) at the top of the membrane elements (3).
- Repeat for the outlet manifold (4) at the bottom of the membrane elements, and the purge manifold (5) at the bottom rear.
- Remove the hold-down clamps (6).

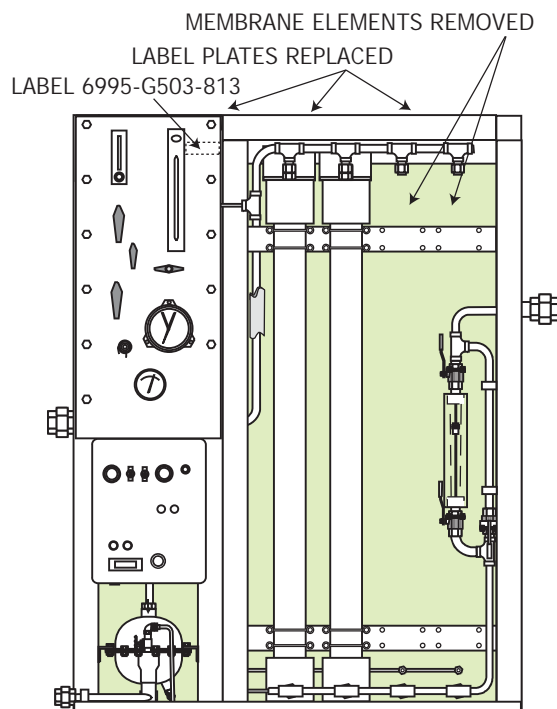

Figure 1. 6995 Mk III MEDG

- Remove the U-bolt clamps (7) securing the membrane elements to the saddles (8) and remove the elements from the dehydrator. Remove the saddles.
- Install the blank bodies supplied in the kit (9) and (10) in the open manifold ports, using lightly lubricated new O-rings (11) and (12) in the tubing fittings.
- On the top surface of the dehydrator, replace the Mk II label plates with the Mk III label plates supplied in the kit. Secure the label plates using the drive screws.
- Install label plate 6995-G503-813 "Purge Flowmeter" as shown.
- Restart the dehydrator in accordance with Paragraph 2.3.2 of the technical manual. Check for air leaks before releasing for service.

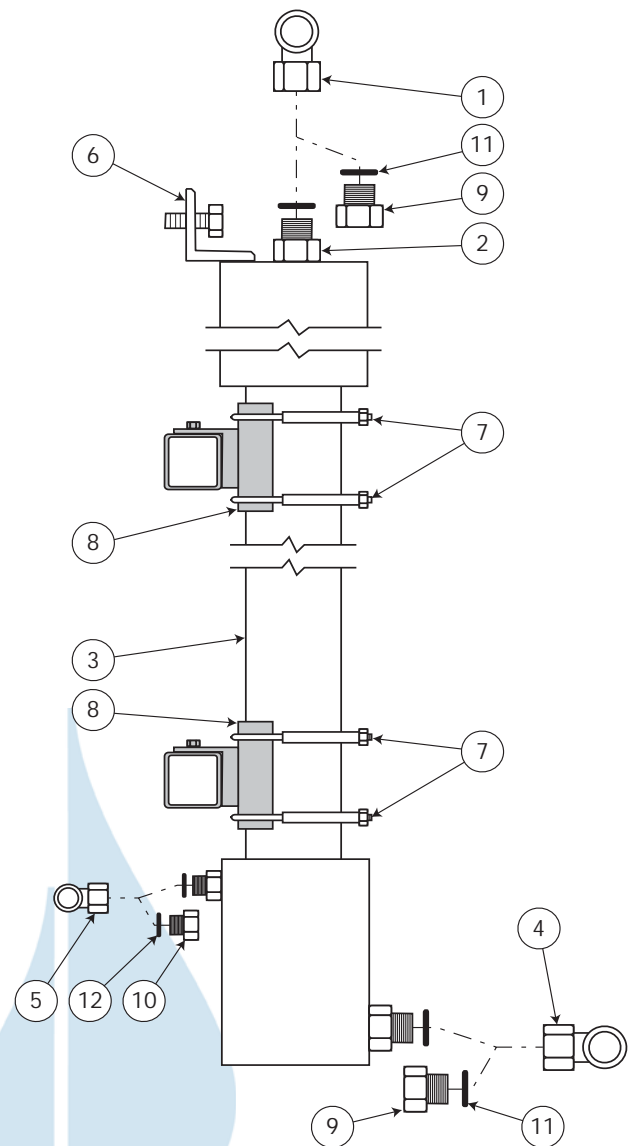

Figure 2. Membrane Installation

Howell Laboratories, Inc.

188 Harrison Rd.
Bridgton, Maine 04009
(207) 647-3327

(888) 744-8359

FAX (207) 647-8273

e-mail: contracts@howelllabs.com
An Employee-Owned Company

web: www.howelllabs.com
Certified to ISO 9001