

Model 7060 Mk II Upgrade

Upgrading Model 7060 Mark II (Part No. 7560-G501) MIOX Electrolytic Disinfectant Generators iaw SCD 2128

Order upgrade kit P/N 8504-G501.

I. Secure and tag out.

Materials:

- Technical manual, NAVSEA S9531-CV-MMA-010.

WARNING

The MEDG operates on 115 VAC. This voltage can kill or injure. Work on an energized electrical system should be performed only by a qualified electrician. Otherwise, when performing repairs, secure and tag out the unit.

WARNING

Be careful to depressurize the MEDG air system before beginning work. Sudden release of air pressure may result in personal injury or death.

NOTE

Item numbers in this procedure refer to callouts on all the illustrations.

- Press the Power button (1). This forces the unit into Standby mode. The electrolytic cell is flushed to deter mineral buildup.
- Close the shutoff valves in the air and fresh water lines, external to the unit. This isolates the MEDG from ship's services. The operating display (2) will show "LOW VENT FLOW" to signal the depressurization of the inlet air line.

Overall View

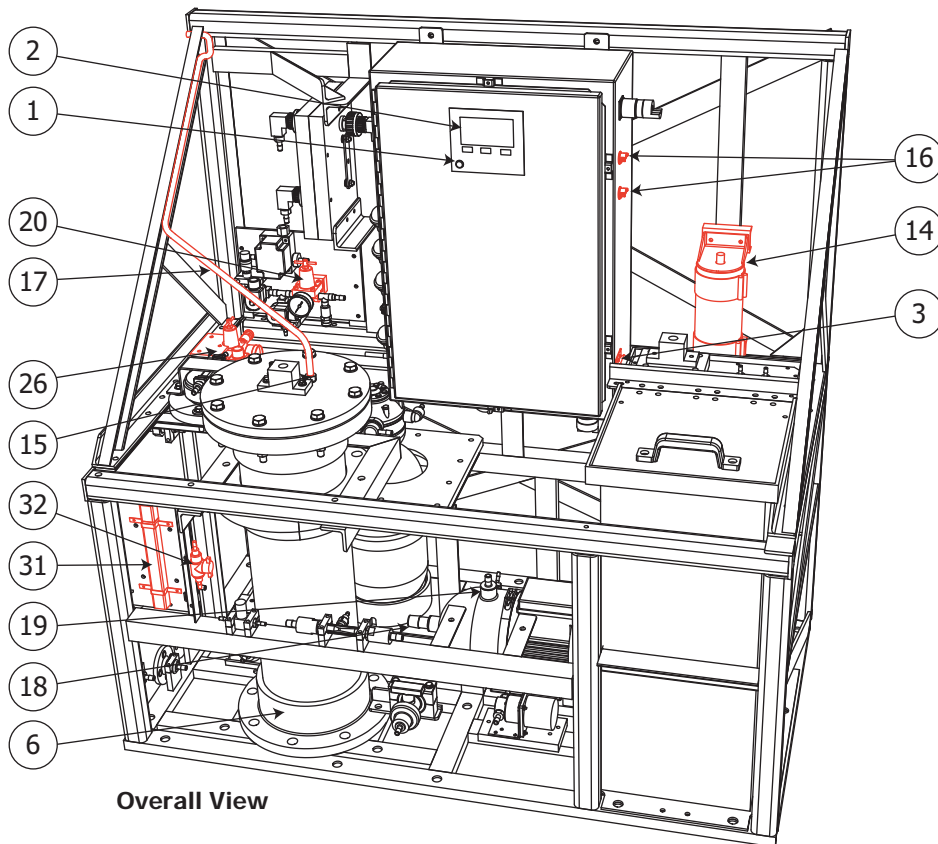

NOTE

At step j of the self-diagnosis procedure, wait until water pressure has been released before proceeding.

- Using the self-diagnostic routine (see paragraph 2.4 of the technical manual), depressurize the water system by opening the brine tank solenoid valve.
- Wait 30 seconds, then turn the circuit breaker/power-on switch (3) OFF. This stops electric power to the control system and closes the inlet water and brine tank solenoid valves. The unit is now shut down.
- Disconnect electrical power, external to the unit.
- Secure the inlet water line (labeled "Potable Water In, 1/4 IPS") external to the unit.
- Secure the fresh water inlet line (labeled "Fresh Water In, 1 IPS") external to the unit.
- Secure the mixed oxidant solution line (labeled "To Spool Piece") external to the unit.
- Place safety locks and tags on the electrical power disconnect and all the water and air valves, according to shipboard procedure.

II. Replace the original PVC mixed oxidant tank level switch with a CPVC switch.

Materials:

- Level switch P/N 7302-01, quantity 1.
- Cover gasket P/N 7469-01, quantity 1.
- Hex head screw, 1/2-13 x 3-1/2" Nylon, quantity 8.
- Hex nut, 1/2-13 Nylon, quantity 8.
- Flatwasher, 1/2" Nylon, quantity 16.

Howell Laboratories, Inc.

188 Harrison Rd.
Bridgton, Maine 04009

(207) 647-3327

(888) 744-8359

e-mail: contracts@howelllabs.com

An Employee-Owned Company

FAX (207) 647-8273

web: www.howelllabs.com

Certified to ISO 9001

Procedure:

CAUTION

Be careful not to lose the bushings around the cover screws.

- Remove the screws (7) securing the mixed oxidant tank cover (8) to the tank (6), and lift the cover. The switch assembly (5) will come out with the cover.
- Carefully measure the switch length from the inside face of the cover to the bottom end of the switch assembly. Note the length.
- Remove the cap (9). Cut the electrical leads (10) between the cap and the cover, as close as possible to the cover. Leave the leads in place in the conduit to aid in drawing the leads of the new switch through the conduit.
- Remove the locking nut (11) securing the switch assembly to the cover. Unscrew the switch assembly from the cover and remove the switch assembly.
- Replace the cover gasket (12).
- Screw the new level switch assembly (5) provided with the upgrade kit into the cover until its length is the same as measured in step b above. Secure it in place using the locking nut (11).

CAUTION

Be careful not to damage the level switch assembly. If the level switch is damaged, it may not control the mixed oxidant level properly.

CAUTION

The bottom end of the level switch extends into a recess (13) in the floor of the tank. Properly seating the end of the switch in the recess is an important step. If the level switch is too long, it will bow, causing it to malfunction.

NOTE

Several minor adjustments and refitting steps may be necessary to get the switch installed properly.

- Reinstall the tank cover with the new level switch, taking care to insert the end of the level switch into the recess (13) in the bottom of the tank. Secure it in place with the new hardware from the upgrade kit.
- Use the leads left in the conduit in step c above to pull the electrical leads of the new switch through the conduit. Attach them to terminals J5-08, J5-20, J5-24, J7-13, and J7-14 (shown in blue in the figure on page 4) in the control panel in place of the original leads.
- Reinstall the cap (9) on the cover.

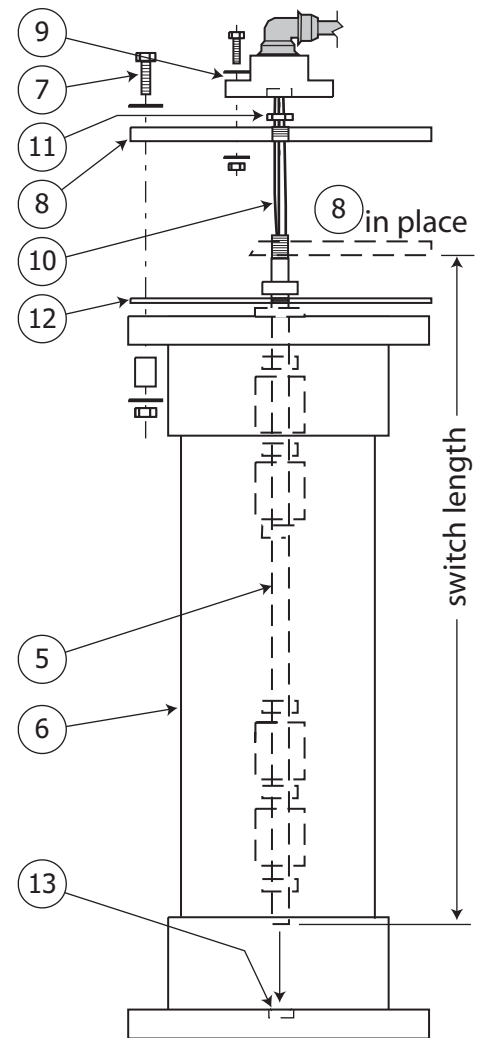

Mixed Oxidant Tank and Level Switch

III. Replace the hydrogen recombiner with a simple vent.

Materials:

- Hole seal P/N 2655-44, quantity 1.
- Hose barb P/N 7390-6-6, quantity 1.
- O-ring P/N M83248/2-906, quantity 1.
- Vent hose P/N 7474-02, quantity 40 in.
- Hose clamp P/N 7476-02, quantity 3.
- Cable ties P/N 8389-2-9, quantity 8.

Procedure:

- Disconnect the tubing from the tubing fitting on the recombiner (14).
- Disconnect the other end of the hose section from the hose barb (15) at the top of the mixed oxidant tank. Remove any ties and remove the hose section from the MEDG.
- In the control panel, disconnect the electrical leads from terminals J101-4L and J101-5L for HTR-1, and from J101-1C and J101-4C for HTR-2. Loosen the strain relief clamps (16) and withdraw the leads from the control panel.
- Remove the top strain relief clamp and plug the hole in the control panel with the plug provided with the upgrade kit.

CAUTION

The heaters may be hot. Allow them to cool before handling them.

- Remove the four screws securing the hydrogen recombiner to the frame, and remove the recombiner.

NOTE

If the hose barb (15) at the top of the mixed oxidant tank is damaged, replace it with the hose barb P/N 7390-6-6 and O-ring P/N M83248/2-906 provided in the upgrade kit.

- f. Connect the vent hose section (17) P/N 7474-02 provided with the conversion kit to the hose barb (15) at the top of the mixed oxidant tank, using one of the hose clamps P/N 7476-02 provided with the upgrade kit.

CAUTION

The hose must be installed with an unbroken upward path, to prevent the formation of an arch, trap, or reverse bend where hydrogen (which is lighter than air) might accumulate. Trapped hydrogen is a severe fire and explosion hazard.

- h. Run the hose up along the left-hand diagonal frame member, as shown, and secure it using cable ties P/N 8389-2-9 from the upgrade kit.

IV. Install isolation valves on the booster pump inlet and outlet.

Materials:

- 1" Ball valve assembly P/N 7450-G504, quantity 1.
- Hose clamp P/N 52750-M-20H, quantity 2.
- 1/2" Ball valve assembly P/N 7450-G506, quantity 1.
- Hose clamp P/N 7476-03, quantity 2.
- Cable ties P/N 8389-2-9, quantity 8.

Procedure:

- a. Locate the 1" diameter hose section at the booster pump inlet (18). Remove cable ties as necessary to access the hose section.

CAUTION

To prevent hose collapse and pump cavitation, the booster pump inlet hose must be reinforced (Howell Laboratories P/N 7474-04 or equivalent).

- b. The 1" ball valve assembly P/N 7450-G504 in the upgrade kit is to be mounted in the 1" booster pump inlet hose. Cut the hose section so that the cut ends can be attached to the hose barbs on the valve, about 12 inches from the inlet flange.
- c. Install hose clamps P/N 52750-M-20H loosely on the hose ends. Install the hose ends on the valve and tighten the hose clamps. Secure the valve and hose by cable-tying the hose to a nearby frame member.
- d. Repeat steps a through c for the 1/2" ball valve P/N 7450-G506 and the 1/2" hose between the injector outlet and the 1/2" titanium flange, using hose clamps P/N 7476-03. Secure the hose sections as necessary, using cable ties P/N 8389-2-9.

V. Replace the steel hardware in the water pressure regulator with stainless hardware.

Materials:

- Hex head screw, 1/4-20 X 3/4" Nylok, quantity 2.
- Flat washer, 1/4", quantity 2.
- Jam nut, 3/8-24, quantity 1.
- Adjustment stem, P/N 8384-01, quantity 1.

Procedure:

- a. Locate the water pressure regulator (20) at the rear of the frame near the electrolytic cell.
- b. Back out the adjusting screw (21) all the way and remove it from the regulator.

NOTE

The two body screws securing the regulator to its mounting bracket are already stainless and need not be replaced.

NOTE

This procedure will be easier if the top regulator half is held in place during replacement of the body screws. Replace the screws one at a time.

- c. One by one, remove the two body screws (22) securing the upper body half (23) to the lower body half (24) and replace them with the 1/4-20 stainless screws and 1/4" washers provided in the upgrade kit.

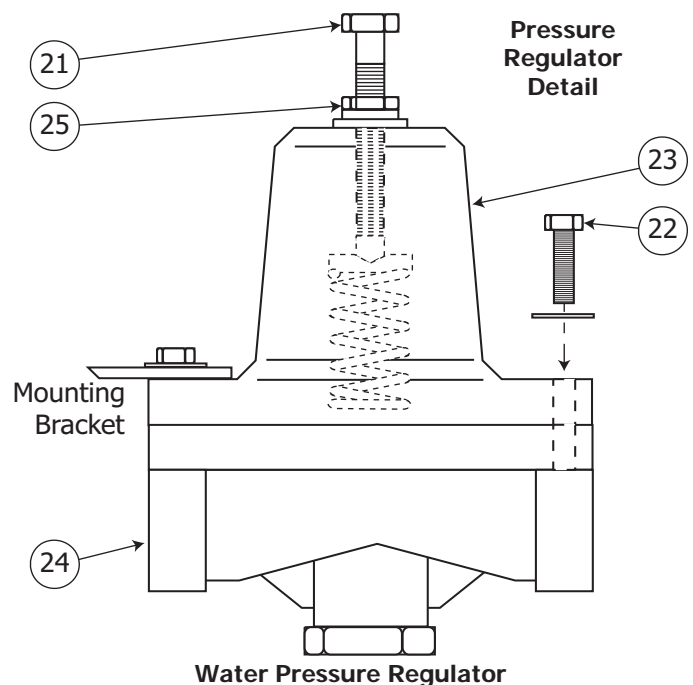

- d. Install the stainless 3/8-24 jam nut (25) provided in the upgrade kit on the threaded section of the stainless adjusting stem 8384-01 provided.

NOTE

Readjustment will be required upon startup.

- e. Install the stainless adjusting stem into the top of the regulator.

VI. Replace the inlet air assembly.

Replace the inlet air assembly (26) with the new one, which contains an air pressure switch, as follows:

Materials:

- Inlet air assembly P/N 7615-G501, quantity 1.
- Terminal block, P/N 8065-10, quantity 1.
- Strain relief, liquid-tight, P/N 8513-CD13NR-BR, quantity 1.
- Hose clamp P/N 7476-02, quantity 2.
- Hex head screw, 1/4-20 x 1-1/2", quantity 2.
- Hex nut, 1/4-20 Nylok, quantity 2.
- Flatwasher, 1/4", quantity 4.

Procedure:

- a. Disconnect the air solenoid valve's coil (27) from the top of the valve stem.

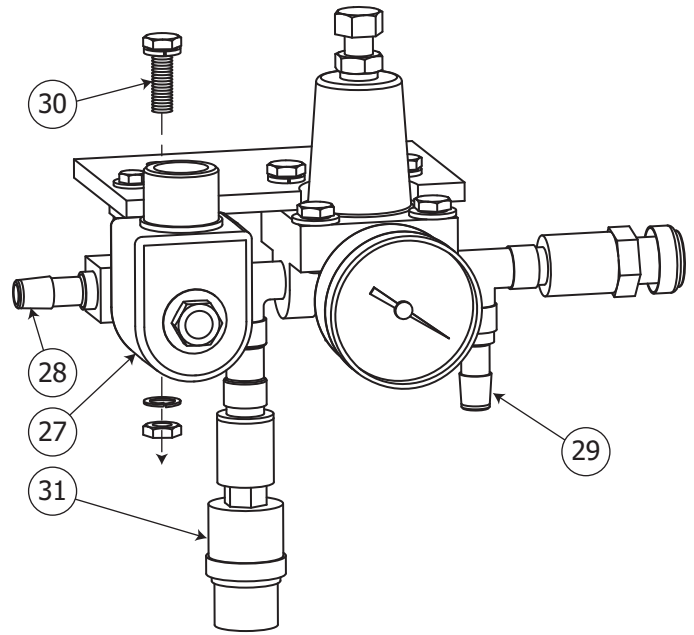

Inlet Air Assembly

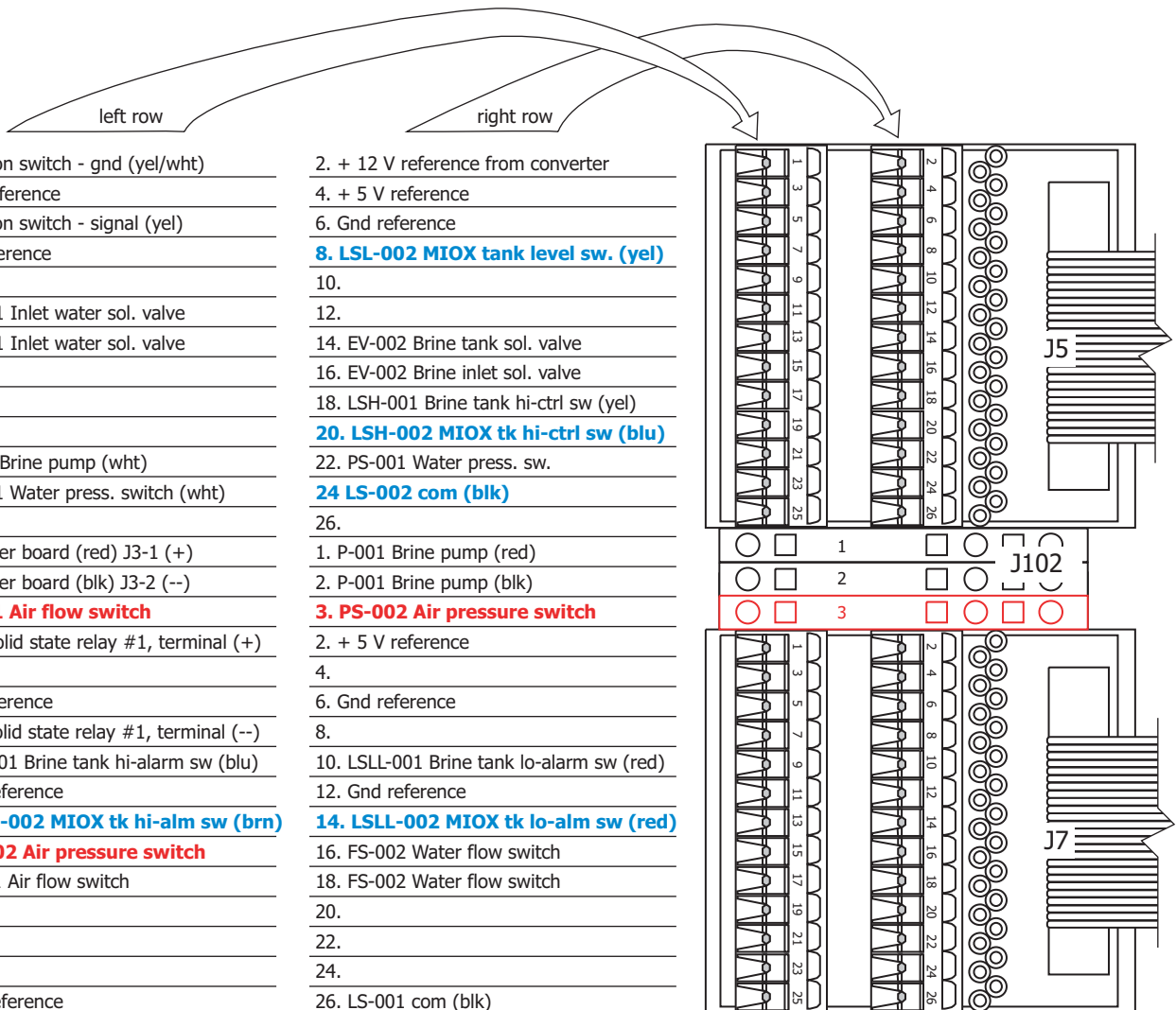

1. Power-on switch - gnd (yel/wht)
3. + 5V reference
5. Power-on switch - signal (yel)
7. Gnd reference
9.
11. EV-001 Inlet water sol. valve
13. EV-001 Inlet water sol. valve
15.
17.
19.
21. P-001 Brine pump (wht)
23. PS-001 Water press. switch (wht)
25.
1. Controller board (red) J3-1 (+)
2. Controller board (blk) J3-2 (--)
3. FS-001 Air flow switch
1. SSR1 Solid state relay #1, terminal (+)
3.
5. Gnd reference
7. SSR1 Solid state relay #1, terminal (--)
9. LSHH-001 Brine tank hi-alarm sw (blu)
11. Gnd reference
13. LSHH-002 MIOX tk hi-alm sw (brn)
15. PS-002 Air pressure switch
17. FS-001 Air flow switch
19.
21.
23.
25. Gnd reference

2. + 12 V reference from converter
4. + 5 V reference
6. Gnd reference
8. LSL-002 MIOX tank level sw. (yel)
10.
12.
14. EV-002 Brine tank sol. valve
16. EV-002 Brine inlet sol. valve
18. LSH-001 Brine tank hi-ctrl sw (yel)
20. LSH-002 MIOX tk hi-ctrl sw (blu)
22. PS-001 Water press. sw.
24 LS-002 com (blk)
26.
1. P-001 Brine pump (red)
2. P-001 Brine pump (blk)
3. PS-002 Air pressure switch
2. + 5 V reference
4.
6. Gnd reference
8.
10. LSL-001 Brine tank lo-alarm sw (red)
12. Gnd reference
14. LSL-002 MIOX tk lo-alm sw (red)
16. FS-002 Water flow switch
18. FS-002 Water flow switch
20.
22.
24.
26. LS-001 com (blk)

Input block - changes shown bold and in color

- b. Disconnect the two air hoses from the air assembly's inlet (28) and outlet (29) hose barbs.
- c. Remove the two screws (30) securing the inlet air assembly to the frame and remove the inlet air assembly.
- d. Install the new inlet air assembly P/N 7615-G501, using the hardware provided in the upgrade kit.
- e. Secure the two air hoses to the air assembly's inlet and outlet hose barbs, using hose clamps P/N 7476-02.
- f. Reattach the solenoid valve's coil to the top of the valve stem.
- g. Install the new terminal block 8065-10 in section J102.
- h. Using the strain relief provided with the upgrade kit, insert the electrical leads from the new air pressure switch (31) into the control panel through the second hole in the control panel (left open in step IIIId).
- i. On the input block (shown in red in the figure on page 4), remove the air flow switch lead from J7-15L and attach it to J102-3L as shown in red above.
- j. Connect the electrical leads from the new air pressure switch (they are interchangeable) to J102-3R and J7-15 as shown.

VII. Install an isolation valve on the mixed oxidant injection line.

Materials:

- Isolation valve assembly P/N 7637-G501, quantity 1.
- Hose clamp P/N 7476-01, quantity 2.
- Cable ties P/N 8389-2-9, quantity 2.

Procedure:

- a. Locate the hose section between the flowmeter (31) and the metering valve (32). Remove cable ties as necessary to access the hose section.
- b. Cut the hose section and insert the isolation valve provided with the upgrade kit, using hose clamps P/N 7476-01 provided with the upgrade kit at each of the hose barbs.
- c. Resecure the hose section and the valve as necessary.

VIII. Restart.

Materials:

- Technical manual, NAVSEA S9531-CV-MMA-010.

Procedure:

- a. Start the MEDG in accordance with Paragraph 2.2.2 of the technical manual.
- b. Adjust the air pressure and water pressure, in accordance with Paragraphs 6.4 and 6.6 of the technical manual respectively.
- c. Monitor the unit in accordance with Paragraph 2.3 of the technical manual.