

# Dew Point System Upgrade

## Switching to the New Sensor

Howell Laboratories Model 4870 Air Control Panels, Model 6995 low-pressure air dehydrators, and Model 7148 dew point monitors have been originally-equipped with an analog dew point monitoring system consisting of a humidity sensor, an electrical enclosure, and a cable connecting the two.

The original-equipment sensor is no longer available. Therefore, you have received an upgraded sensor with integral wiring harness. The new assembly mates with the cable connector on the latest enclosures, P/N 7006-G503, Revision M or later. Earlier enclosure configurations (7006-G50x through Rev. L) have a connector that does not match the new cable.

Your version will be easy to identify; earlier ones are equipped with an analog humidity meter, while the later versions have a digital dew point indicator.

This kit is provided to enable you to convert an older enclosure to work with the new sensor and cable.

### I. Tools required:

- Molex crimping tool no. 0638191300 or equivalent.
- Wire cutters.
- Allen wrench, 0.050".
- Ohmmeter.

### II. Materials required:

1. Harness, sensor connector P/N 8732-G501, qty 1, including:
  - 2. Terminal, crimp, socket P/N 8347-02065100, qty 3.
  - 3. Housing, crimp, plug P/N 8347-03062044, qty 1.
  - 4. Nut, retaining P/N 8551-01, qty 1.
  - 5. Receptacle, cable connecting P/N MS3111-E8-4P, qty 1.
  - 6. Housing, crimp, receptacle P/N 8347-03061044, qty 1.
7. Harness, Potentiometer P/N 8732-G502, including:
  - 8. Terminal, crimp, socket P/N 8347-02065100, qty 3.
  - 9. Housing, crimp, plug P/N 8347-03062044, qty 1.
  - 10. Potentiometer, 10 K $\Omega$  P/N 4705-07, qty 1.
11. Sensor with cable harness P/N 8639-G501, qty 1.

### III. Shut down and tag out:

Shut the equipment down and tag it out in accordance with shipboard procedure and the instructions in the technical manual.

### IV. Install the new connector:

- a. Locate the existing sensor cable connector in the bottom left floor of the enclosure.
- b. Inside the enclosure, cut the wires near the connector. Unscrew the retaining nut and remove the existing connector.
- c. Install the socket crimp terminals (2) onto the cut wires (step b) inside the enclosure.
- d. Plug the wires into the plug crimp housing (3): blue into port #3, orange into port #2, and black into port #1.

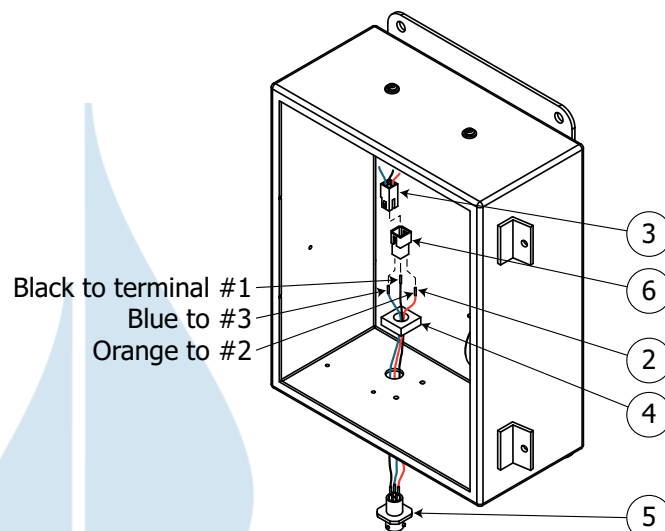

Figure 1. Sensor connector harness installation

## Howell Laboratories, Inc.

188 Harrison Rd.  
Bridgton, Maine 04009

(207) 647-3327

(888) 744-8359

FAX (207) 647-8273

e-mail: [contracts@howelllabs.com](mailto:contracts@howelllabs.com)

web: [www.howelllabs.com](http://www.howelllabs.com)

- e. Feed the new sensor connector harness (1) through the opening left by the old receptacle. Slip the nut (4) over the wires and secure the new receptacle (5) to the enclosure.
- f. Plug the harness wires into the receptacle crimp housing (6) in the same manner as in step d above.
- i. Plug the plug crimp housing (3) into the receptacle crimp housing (6).
- j. Using an ohmmeter, confirm the continuity of the three wires from the enclosure connector to the terminal point on the board.

## V. Install the new potentiometer:

- a. Locate the existing potentiometer at the lower front of the enclosure.
- b. Inside the enclosure, cut the wires near the potentiometer.
- c. Back off the set screw and remove the potentiometer dial.
- d. Unscrew the retaining nut and remove the existing potentiometer.
- e. Install the socket crimp terminals (8) on the cut wires (step b) inside the enclosure.
- f. Plug the wires into the plug crimp housing (9): green into port #3, gray into port #2, and black into port #1.
- g. Install the new potentiometer (10) in the opening in the front of the enclosure, and install the new dial on the potentiometer shaft.
- h. Plug the plug crimp housing (9) into the receptacle crimp housing, factory-installed on the potentiometer harness.
- i. Using an ohmmeter, confirm the continuity of the three wires from the enclosure connector to the terminal point on the board.

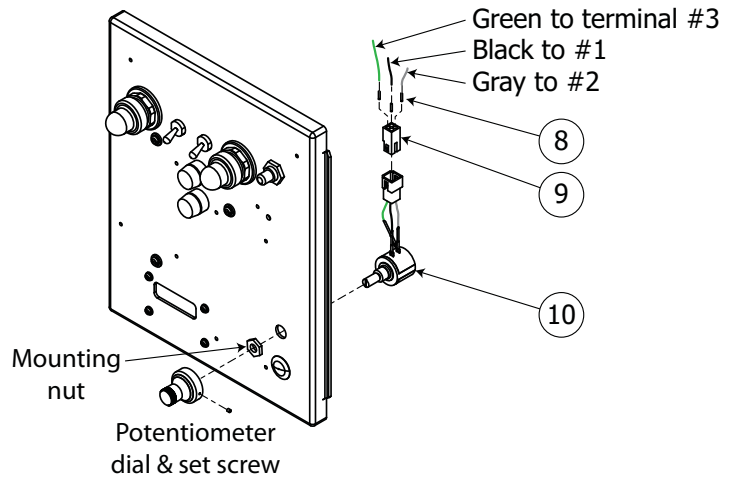

**Figure 2. Potentiometer harness installation**

## VI. Install the new sensor:

- a. Remove the existing sensor from its port in the equipment piping and install the new sensor (11).
- b. Plug the new sensor harness into the new cable connecting receptacle (5).

## VII. Calibrate:

Calibrate the dew point monitoring system in accordance with the instructions in the equipment technical manual.